



September 26, 2019

Mr. Bruce Weber
Planning/Zoning Office
Town of Cortlandville
3577 Terrace Road
Cortland, NY 13045

RE: Conditional Permit Application, Area Variance Application
Used Car King - Sun Auto Cortland- 3845 West Rd Rte. 281
Tax Map No. 86.17-02-03.0
CHA Project No. 058214

Dear Mr. Weber:

CHA Consulting, Inc., on behalf Used Car King, LLC (Owner/Applicant), is pleased to submit the enclosed Conditional Permit and Area Variance Application as it relates to a proposed exterior improvements project for the above referenced site. The proposed modifications on this lot include demolition of one building, exterior facade improvements to the remaining existing building, site lighting, site signage, closing a curb cut to Route 281, pavement removal and landscaping improvements, and proposed pavement and striping. The Owner is seeking an Area Variance for the project that proposes greater than 500 sf of impervious installation. The site modifications will result in less than 50% greenspace coverage in the Wellhead Protection Zone 1a. The variance is requested primarily to provide safe, internal vehicle and pedestrian traffic circulation between site and the newly acquired adjacent parcel without the need to travel onto Route 281. The proposed light pole sign banners and one freestanding sign will enhance the aesthetics of the parking lot and bring cohesiveness between the two adjacent lots. The signage updates are consistent with the latest brand requirements the Used Car King stores. Area Variance request specifics are attached to the application form.

The following items are included with this permit package:

- Conditional Permit Application
- Area Variance Application
- Short Environmental Assessment Form
- Zoning Referral Form
- Civil Site Plans "Proposed Parking Lot Modifications" by CHA, dated 09/26/2019
- Check for Fees: \$350 (\$250 Conditional Permit, \$100 Area Variance)

Should you have any questions related to the submission, please do not hesitate to contact me at 315-471-3920 or avitale@chacompanies.com

Sincerely,

A handwritten signature in blue ink, appearing to read 'Anthony Vitale', is written over a light blue horizontal line.

CHA Consulting, Inc.
Anthony Vitale, Senior Engineer V

Enclosures

Cc: Mr. Daniel King (Owner)

V:\Projects\ANY\K5\058214.000\Permitting\0 - Conditional Permit App Cover-01-11.1.doc

**TOWN OF CORTLANDVILLE
3577 TERRACE ROAD
CORTLAND, NEW YORK 13045-3552**

APPLICATION FOR CONDITIONAL PERMIT

APPLICANT

Name UCK Three, LLC Fee Paid _____
Address 8010 Brewerton Road Phone (315) 698-6808
Cicero, NY 13039

PROPERTY OWNER

Name Same as Applicant Phone _____
Address _____

PROPERTY INFORMATION

Location of property 3845 Rt. 281
Tax Map No. of Parcel 86.17-02-03.0

PROPERTY ACQUIRED ON, OR PENDING DATE OF ACQUISITION _____
IS PROPERTY IN FLOOD PLAIN? YES NO

ZONING DISTRICT B-3

PROJECT DISCRPTION Connecting the parking lots of 3861 Rt. 28 and 3845 Rt. 281, Cortland, NY 13045.
Removing one existing building and small grassy area for asphalt parking/driveway. Eliminating one curb cut from Rt 281.
Proposed exterior facade improvements to Detailing Building, site lighting, and signage for brand compliance and
uniformity between the sites.

Information to be included will be drawn from a checklist in Article XIV of the
Cortlandville Zoning Law.

DATE OF APPLICATION 09/20/2019

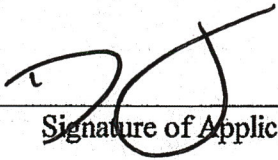

Signature of Applicant

Zoning Officer

Planning Board Chairperson

PERMIT GRANTED _____

PERMIT DENIED _____

TOWN OF CORTLANDVILLE
3577 TERRACE ROAD
CORTLAND, NY 13045

ZONING BOARD OF APPEALS
AREA VARIANCE FINDINGS & DECISION

Applicant: UCK Three, LLC Phone#: (315) 698-6808

Address: 8010 Brewerton Road, Cicero, NY 13039 Fee: _____

Property Owner: Same as Applicant

Appeal Concerns Property at the following address: 3845 Rt. 281, Cortland, NY 13045

Tax Map #: 86.17-02-03.0

Zoning District Classification: B-3

Use for which Variance is requested: Less than the 50% greenspace in Wellhead Protection Zone 1a.
Light pole sign banner: sign area, mounting height, 15 ft property line setback. SWPPP Report.
Free standing sign: sign height.

Applicable Section(s) of Zoning code: Article IA 178-2.2, Article XVIII 178-113, Article XVI 178-90 C.1

Signature:  Date: 09/20/2019

TEST: No area variance will be granted without a consideration by the board of the following factors:

1. Whether an undesirable change would be produced in character of neighborhood or a detriment to nearby properties: Yes _____ No X

Reason: Please see attached.

2. Whether benefit sought by applicant can be achieved by feasible alternative to the variance: Yes _____ No X

Reason: Please see attached.

Zoning Board of Appeals Area Variance Findings & Decision

3. Whether the requested variance is substantial: Yes _____ No X

Reason: Please see attached.

4. Would the variance have an adverse impact on the physical or environmental conditions in the neighborhood: Yes _____ No X

Reason: Please see attached.

5. Whether the alleged difficulty was self-created: Yes _____ No X

Reason: Please see attached.

DETERMINATION OF ZBA BASED ON THE ABOVE FIVE FACTORS:

The ZBA, after taking into consideration the above five factors, finds that:

_____ The Benefit to the Applicant DOES NOT outweigh the Detriment to the Neighborhood or Community and therefore the variance request is denied.

_____ The benefit to the Applicant DOES outweigh the Detriment to the Neighborhood or Community.

Reason: _____

Area Variance Findings & Decision Application

Project Site: 3845 West Road Lot 3.0

Variance Requests:

- Less than the 50% greenspace in Wellhead Protection Zone 1a. Any change in the size of an existing building, structure, parking lot and/or driveway that is 500 square feet or more shall result in a reduction of the amount of the parcel's impervious surface by 5%.
- Light pole banner signs: sign area, 8 ft height, 15 ft property line setback.
- Freestanding Sign: 8 ft sign height.
- SWPPP Report Preparation. Development projects or subdivisions which result in less than one acre of land disturbance, and which result in an increase in impervious surface less than 10,000 square feet, and which result in a total impervious surface less than 35% of the total post development lot area.

1. Character of Neighborhood:

The parking lot improvements that result in a post-development impervious area greater than 50% will not detract from the character of the neighborhood. The driveway connection will unify the two sites into one and will decrease the impervious area 3% (from 85% to 82% or 1,545 sf) on this parcel. A vegetated grass strip is proposed across the Route 218 frontage to mimic the look of the adjacent site for this project. The Route 281 corridor is a commercial corridor that is heavily developed, and this project is consistent with existing land uses and site conditions in the corridor. The project is also proposing to remove pavement in the right-of-way which has not been included in the overall lot coverage calculations.

The proposed banner signs are required for continued brand compliance. They will enhance the aesthetics of the parking lot and bring cohesiveness between the two adjacent lots, now under one dealership.

The proposed freestanding sign is in character for the neighborhood that includes multiple car dealerships.

Although, the current site exists at over 35% impervious area, the proposed improvements remove 1,545 square feet of existing pavement and the total project is less than 10,000 square feet of new impervious with less than one acre of land disturbance. The current site has existing structural stormwater BMPs (best management practices) in place and will be utilized to control the minimal increase in stormwater from this project. The Route 281 corridor is heavily developed with closed drainage systems and this project will continue to maintain the stormwater drainage system on site to control pollutants from entering the groundwater.

2. Feasible Alternative:

Multiple design iterations were created to minimize the increase in impervious area and still provide a logical paved connection between the two lots that is currently lacking. Existing

pavement is also being removed where it is not needed. This design reduces the impacts and maximizes the internal circulation of vehicles between the two properties without having the need to enter and exit onto Route 281. The project will add to the overall internal vehicle and pedestrian circulation. The proposed closing of one of the curb cuts onto Route 281 will alleviate traffic congestion on Route 281 entering and exiting the site as there where two curb cut in close proximity to each other.

The light pole banner signs are required for brand compliance. The style and size of the banner signs provides a proportional sign area that is visually effective without being overpowering to the size and scale of the light poles and parking lot area. The mounting heights are based upon standard guidelines and lower mounting height would hinder placement of display vehicles in the parking lot.

The proposed freestanding sign will replace the two existing signs on this lot and is proposed at a maximum distance away from the other existing, identical sign on the adjacent lot.

The project reduces impervious square footage for an existing developed site, and minimal land disturbance with negligible impacts to current or future stormwater management. As part of construction, the project will include standard erosion and sediment control practices (BMPs).

3. Requested Variance is substantial:

The requested greenspace variance is not substantial. The impervious area for this lot will be reduced by 3% and the overall project will only increase total impervious area by 1% for both lots. A large portion of pavement on this lot will be removed and revegetated. The project is also proposing to remove pavement in the right-of-way which has not been included in the overall lot coverage calculations.

The light pole banner signs are required for brand compliance and will only add to the aesthetics of the site, parking lot, and create a softer commercial feel to the site. The banners will effectively utilize proposed light poles on this site.

The proposed freestanding sign replaces two existing signs and meets the square footage requirement of under 90 sf (80.75 sf proposed).

The small increase in pavement for the overall project is not substantial and standard erosion and sediment control practices (BMPs) will be put into place during construction. The need for a SWPPP report for the small increase in pavement on the existing developed sites will not provide substantially different results.

4. Adverse Physical or Environmental Impact:

The total proposed amount of pavement to make the paved connection between the lots is minor and will have little to no effect on the physical or environmental conditions of the neighborhood and is in keeping with the elements of the corridor.

The proposed light pole banner signs will enhance the aesthetics of the parking lot and utilize proposed light poles.

The proposed freestanding sign replaces two existing signs and will have little to no effect on the physical or environmental conditions of the neighborhood.

The small increase in pavement for the overall project is not substantial and stormwater management BMPs and standard erosion and sediment control practices (BMPs) either currently exist on the site or will be put into place during construction to control erosion and sedimentation and will facilitate the removal of pollutants in stormwater runoff to maintain groundwater quality.

5. Difficulty was self-created:

The existing project site is a developed and functioning car dealership with less than 50% greenspace. This parcel was acquired for its proximity to the existing car dealership. The addition of a paved connection provides internal access which does not exist. By adding the connection, the project can provide internal circulation that is currently lacking and would cause vehicles to enter and exit onto Route 281 in order to access each site. Also, the closing of a curb cut to Route 281 will provide access management along Route 281 and limit the number of driveways to the site, which provides for safer vehicle and pedestrian movements.

The light pole banner signs are required for brand compliance and will unify the two adjacent sites to create an appealing and active commercial site at a key intersection in the Town.

The proposed freestanding sign replaces two existing signs and is of identical size and style as the existing sign on the adjacent car dealership. The proposed sign height is by design to be visible and in line with branding requirements.

After many iterations, the design with the least environmental impact and smallest effective impervious area to make a useful paved connection was chosen and presented on the plans.

Short Environmental Assessment Form

Part 1 - Project Information

Instructions for Completing

Part 1 – Project Information. The applicant or project sponsor is responsible for the completion of Part 1. Responses become part of the application for approval or funding, are subject to public review, and may be subject to further verification. Complete Part 1 based on information currently available. If additional research or investigation would be needed to fully respond to any item, please answer as thoroughly as possible based on current information.

Complete all items in Part 1. You may also provide any additional information which you believe will be needed by or useful to the lead agency; attach additional pages as necessary to supplement any item.

Part 1 – Project and Sponsor Information			
Name of Action or Project: Sun Auto Parking Lot Modification			
Project Location (describe, and attach a location map): 3845 West Road, Cortland, NY 13045, Lot 3.0			
Brief Description of Proposed Action: Site improvements including but not limited to building demolition, closing a curb cut, paving, striping, light poles, additional signage. The project proposes to make a paved connection between 3861 and 3845 West Road (Rte 281) for internal site vehicle and pedestrian circulation.			
Name of Applicant or Sponsor: UCK THREE, LLC / CHA CONSULTING, INC. (c/o James Trasher)		Telephone: 315-471-3920	
Address: 8010 Brewerton Road		E-Mail: jtrasher@chacompanies.com	
City/PO: Cicero		State: NY	Zip Code: 13039
1. Does the proposed action only involve the legislative adoption of a plan, local law, ordinance, administrative rule, or regulation? If Yes, attach a narrative description of the intent of the proposed action and the environmental resources that may be affected in the municipality and proceed to Part 2. If no, continue to question 2.		NO <input type="checkbox"/>	YES <input type="checkbox"/>
2. Does the proposed action require a permit, approval or funding from any other government Agency? If Yes, list agency(s) name and permit or approval: NYS DOT		NO <input type="checkbox"/>	YES <input checked="" type="checkbox"/>
3. a. Total acreage of the site of the proposed action? _____ 1.32 acres			
b. Total acreage to be physically disturbed? _____ 0.20 acres			
c. Total acreage (project site and any contiguous properties) owned or controlled by the applicant or project sponsor? _____ 6.55 acres			
4. Check all land uses that occur on, are adjoining or near the proposed action:			
5. <input type="checkbox"/> Urban <input type="checkbox"/> Rural (non-agriculture) <input type="checkbox"/> Industrial <input checked="" type="checkbox"/> Commercial <input type="checkbox"/> Residential (suburban)			
<input type="checkbox"/> Forest <input type="checkbox"/> Agriculture <input type="checkbox"/> Aquatic <input type="checkbox"/> Other(Specify):			
<input type="checkbox"/> Parkland			

	NO	YES	N/A
5. Is the proposed action, a. A permitted use under the zoning regulations? b. Consistent with the adopted comprehensive plan?	<input type="checkbox"/>	<input checked="" type="checkbox"/>	<input type="checkbox"/>
	<input type="checkbox"/>	<input checked="" type="checkbox"/>	<input type="checkbox"/>
6. Is the proposed action consistent with the predominant character of the existing built or natural landscape?	NO	YES	
	<input type="checkbox"/>	<input checked="" type="checkbox"/>	
7. Is the site of the proposed action located in, or does it adjoin, a state listed Critical Environmental Area? If Yes, identify: _____	NO	YES	
	<input type="checkbox"/>	<input checked="" type="checkbox"/>	
8. a. Will the proposed action result in a substantial increase in traffic above present levels? b. Are public transportation services available at or near the site of the proposed action? c. Are any pedestrian accommodations or bicycle routes available on or near the site of the proposed action?	NO	YES	
	<input checked="" type="checkbox"/>	<input type="checkbox"/>	
	<input checked="" type="checkbox"/>	<input type="checkbox"/>	
	<input type="checkbox"/>	<input checked="" type="checkbox"/>	
9. Does the proposed action meet or exceed the state energy code requirements? If the proposed action will exceed requirements, describe design features and technologies: _____ _____	NO	YES	
	<input type="checkbox"/>	<input checked="" type="checkbox"/>	
10. Will the proposed action connect to an existing public/private water supply? If No, describe method for providing potable water: _____ _____	NO	YES	
	<input type="checkbox"/>	<input checked="" type="checkbox"/>	
11. Will the proposed action connect to existing wastewater utilities? If No, describe method for providing wastewater treatment: _____ _____	NO	YES	
	<input type="checkbox"/>	<input checked="" type="checkbox"/>	
12. a. Does the project site contain, or is it substantially contiguous to, a building, archaeological site, or district which is listed on the National or State Register of Historic Places, or that has been determined by the Commissioner of the NYS Office of Parks, Recreation and Historic Preservation to be eligible for listing on the State Register of Historic Places? b. Is the project site, or any portion of it, located in or adjacent to an area designated as sensitive for archaeological sites on the NY State Historic Preservation Office (SHPO) archaeological site inventory?	NO	YES	
	<input checked="" type="checkbox"/>	<input type="checkbox"/>	
	<input type="checkbox"/>	<input checked="" type="checkbox"/>	
13. a. Does any portion of the site of the proposed action, or lands adjoining the proposed action, contain wetlands or other waterbodies regulated by a federal, state or local agency? b. Would the proposed action physically alter, or encroach into, any existing wetland or waterbody? If Yes, identify the wetland or waterbody and extent of alterations in square feet or acres: _____ _____ _____	NO	YES	
	<input checked="" type="checkbox"/>	<input type="checkbox"/>	
	<input checked="" type="checkbox"/>	<input type="checkbox"/>	

14. Identify the typical habitat types that occur on, or are likely to be found on the project site. Check all that apply: <input type="checkbox"/> Shoreline <input type="checkbox"/> Forest <input type="checkbox"/> Agricultural/grasslands <input type="checkbox"/> Early mid-successional <input type="checkbox"/> Wetland <input type="checkbox"/> Urban <input type="checkbox"/> Suburban		
15. Does the site of the proposed action contain any species of animal, or associated habitats, listed by the State or Federal government as threatened or endangered?	NO	YES
	<input checked="" type="checkbox"/>	<input type="checkbox"/>
16. Is the project site located in the 100-year flood plan?	NO	YES
	<input type="checkbox"/>	<input checked="" type="checkbox"/>
17. Will the proposed action create storm water discharge, either from point or non-point sources? If Yes, a. Will storm water discharges flow to adjacent properties? b. Will storm water discharges be directed to established conveyance systems (runoff and storm drains)? If Yes, briefly describe:	NO	YES
	<input type="checkbox"/>	<input checked="" type="checkbox"/>
	<input checked="" type="checkbox"/>	<input type="checkbox"/>
	<input type="checkbox"/>	<input checked="" type="checkbox"/>
<hr/> <hr/>		
18. Does the proposed action include construction or other activities that would result in the impoundment of water or other liquids (e.g., retention pond, waste lagoon, dam)? If Yes, explain the purpose and size of the impoundment:	NO	YES
	<input checked="" type="checkbox"/>	<input type="checkbox"/>
<hr/>		
19. Has the site of the proposed action or an adjoining property been the location of an active or closed solid waste management facility? If Yes, describe:	NO	YES
	<input checked="" type="checkbox"/>	<input type="checkbox"/>
<hr/>		
20. Has the site of the proposed action or an adjoining property been the subject of remediation (ongoing or completed) for hazardous waste? If Yes, describe:	NO	YES
	<input checked="" type="checkbox"/>	<input type="checkbox"/>
<hr/>		
I CERTIFY THAT THE INFORMATION PROVIDED ABOVE IS TRUE AND ACCURATE TO THE BEST OF MY KNOWLEDGE		
Applicant/sponsor/name: <u>DANIEL KING</u> Date: <u>09/20/2019</u>		
Signature: <u></u> Title: <u>COO</u>		

GENERAL MUNICIPAL LAW

Zoning Referral Form

Conditional Permits, Special Permits, Site Plan Reviews & Variances

Director
CORTLAND COUNTY PLANNING DEPARTMENT
37 Church St.
Cortland, NY 13045-2838
Telephone: (607) 753-5043
Fax: (607) 753-5150

GML No. 86.17-02-03.0
(Tax Map Number)

Date: 09/16/2019

Submitting Officer: Bruce Weber, Planning & Zoning Officer

Municipality: Town of Cortlandville

Mailing Address: 3577 Terrace Road, Cortland, NY 13045

Phone Number: (607) 756-7052

Fax Number: (607) 758-7922

Type of Referral

The applicant request the following:

Variance: X Bulk – Article 178 Section 2.2 | 113 | 90 C.1
Use – Article _____ Section _____

Special Permit: Article _____ Section _____

Conditional Permit: Article 178 Section 31

Site Plan Review: Article _____ Section _____

Reason(s) for request: _____

Is the above action a **Type 1** _____, **Type 2** _____, or unlisted action under the State Environmental Quality Review Act? Attach required environmental assessment forms for Type I and unlisted actions.

The following information is required for your application to be complete:

1. Name of petitioner: UCK Three, LLC

Owners name (if different): _____

Date of acquisition: _____

Address: 8010 Brewerton Road

State: New York Zip: 13039

Phone Number: (315) 698-6808 Fax Number:

2. A Site Plan Map showing:

- a. Scale (1 inch equals 20 feet if site is less than 1 acre or an agreed upon scale for a site larger than 1 acre)
- b. North Arrow
- c. Physical Characteristics of Site, existing and proposed (Topography, Water and Vegetation)
- d. Layout Plan Showing buildings, parking and available utilities
- e. Surface and Subsurface Drainage Plan, incorporated with Layout Plan
- f. Location of County or State facility pursuant to Section 239 l, m and n of the General Municipal Law
- g. Location Map at 1"=1000' scale
- h. Area Map at 1"=200' or an agreed upon scale
 - (1) zoning classification of subject and adjoining properties
 - (2) surrounding land use within 500 feet of subject property
 - (3) surrounding zoning classifications

3. A certified Tax Map from the Cortland County Office of Real Property and Assessment showing the property lines of the applicant's property.

4. Availability of public utilities and services:

Water YES District B-3 ; Sewer YES District B-3 ;

Fire Protection YES District B-3 ; Refuse Collection YES

Special services required: _____

5. Does Site Plan conform to municipal master plan? YES If not why? _____

6. Does Site Plan conform to county land use plan? YES If not why? _____

7. School District: Cortland Enlarged City School District

8. Projected energy consumption: _____ Type: _____

9. Traffic generation (expected vehicle departures and arrivals per 24 hour period) : No change

NOTE: All maps require the name and address of the N.Y.S. licensed engineer or land surveyor responsible for preparing the seal and map.

Signature and Title of Submitting Official

(REVISED: 8/01)

ADDITIONAL INFORMATION - IF APPLICABLE

CHECK	VENDOR	VENDOR NAME			CHECK DATE
222021	112664	TOWN OF CORTLANDVILLE			9/20/2019
INVOICE	INVOICE DATE	INVOICE AMOUNT	DISCOUNT	AMOUNT PAID	MEMO INFORMATION
	9/20/2019	350.00	.00	350.00	PERMIT
		INVOICE TOTAL	DISCOUNT TOTAL	PAID TOTAL	CUSTOMER NUMBER
REMITTANCE ADVICE		350.00	.00	350.00	

© 2016 DEALERTRACK TECHNOLOGIES - Dealership Application Group

19402

B_MCBW

SUN CHEVROLET
104 W. Genesee St.
Chittenango, NY 13037

THE FACE OF THIS DOCUMENT HAS A COLORED BACKGROUND ON WHITE PAPER



8010 Brewerton Rd
Cicero, NY 13039
Phone: (315) 698-6808

SU2 - M&T BANK
10-4/220

DATE	CHECK
9/20/2019	222021

AMOUNT
\$ 350.00

Pay Three Hundred Fifty Dollars and no/Cents

TO
THE
ORDER
OF

TOWN OF CORTLANDVILLE
3577 TERRACE ROAD
CORTLAND, NY 13045



[Handwritten Signature]

THE BACK OF THIS DOCUMENT CONTAINS CHECK SECURITY WATERMARK AND COIN REACTIVE INK

⑈000222021⑈ ⑆022000046⑆

9835698169⑈

PROPOSED PARKING LOT MODIFICATIONS

3861 & 3845 WEST RD (NYS ROUTE 281) TOWN OF CORTLANDVILLE, NEW YORK

CORTLANDVILLE TOWN BOARD

CORTLANDVILLE TOWN BOARD

RICHARD C. TUPPER, SUPERVISOR
TED TESTA, COUNCILOR
JOHN C. PROUD, COUNCILOR
DOUGLAS WITHEY, COUNCILOR
RANDY ROSS, COUNCILOR

KRISTIN E. ROCCO-PETRELLA, RMC, TOWN CLERK

CORTLANDVILLE PLANNING BOARD

KATHERINE S. WICKWIRE, CHAIR
LAIRD UPDYKE
CHRISTOPHER B. NEWELL
NASRIN PARVIZI
NICHOLAS A. RENZI

SITE LOCATION MAP

SCALE: NTS

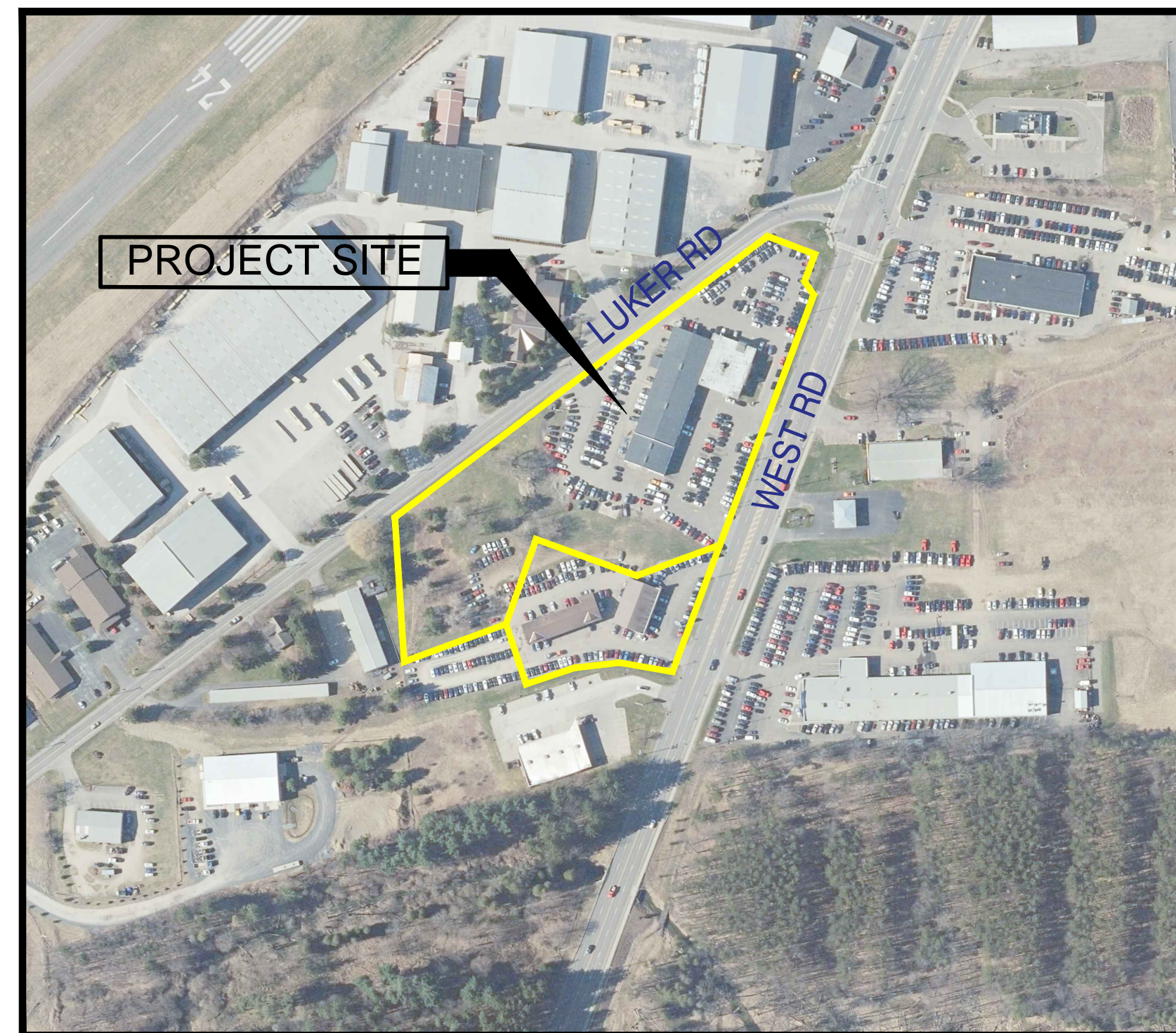
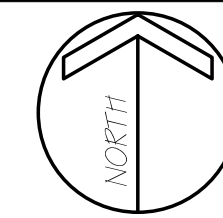

DRAWING INDEX

Sheet No.	Sheet Title
C-01	TITLE SHEET
C-02	LEGEND & GENERAL NOTES
C-03	EXISTING CONDITIONS & DEMOLITION PLAN
C-04	LAYOUT PLAN
C-05	LANDSCAPING PLAN
C-06	LIGHTING & SIGNAGE PLAN

SEPTEMBER 2019

OWNER:

USED CAR KING, LLC

8010 BREWERTON RD

CICERO, NY 13039

Drawing Copyright © 2019



300 South State Street, Suite 600
Syracuse, NY 13203-4712
315.471.3920 • www.chacompanies.com

APPLICANT:
USED CAR KING, LLC
8010 BREWERTON RD
CICERO, NY 13039

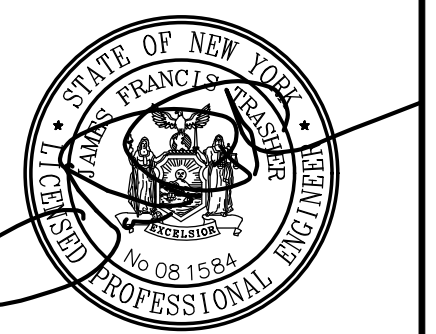

IT IS A VIOLATION OF LAW FOR ANY PERSON, UNLESS THEY ARE ACTING UNDER THE SUPERVISION OF A LICENSED PROFESSIONAL ENGINEER, ARCHITECT, LANDSCAPE ARCHITECT OR LAND SURVEYOR, TO ALTER IN ANY WAY, IF AN ITEM BEARING THE SEAL OF A LICENSED PROFESSIONAL ENGINEER, ARCHITECT, LANDSCAPE ARCHITECT OR LAND SURVEYOR SHALL BEAM, THE SEAL AND INCLUDE THE NOTATION "ALTERED BY" FOLLOWED BY THEIR SIGNATURE, THE DATE OF SUCH ALTERATION, AND A SPECIFIC DESCRIPTION OF THE ALTERATION.

PROJECT:
**PROPOSED PARKING LOT
MODIFICATIONS**
3845 & 3861 WEST RD
CORTLANDVILLE, NY 13045

No.	Submitted / Revision	Appr'd By	Date
0	Town of Cortlandville Submittal	JFT	AMV 09/26/19

TITLE SHEET

Designed By:	Drawn By:	Checked By:
AMV	AMV	JFT
Issue Date:	Project No:	Scale:
9/26/19	58214	AS SHOWN

Drawing No.:

C-01

LEGEND

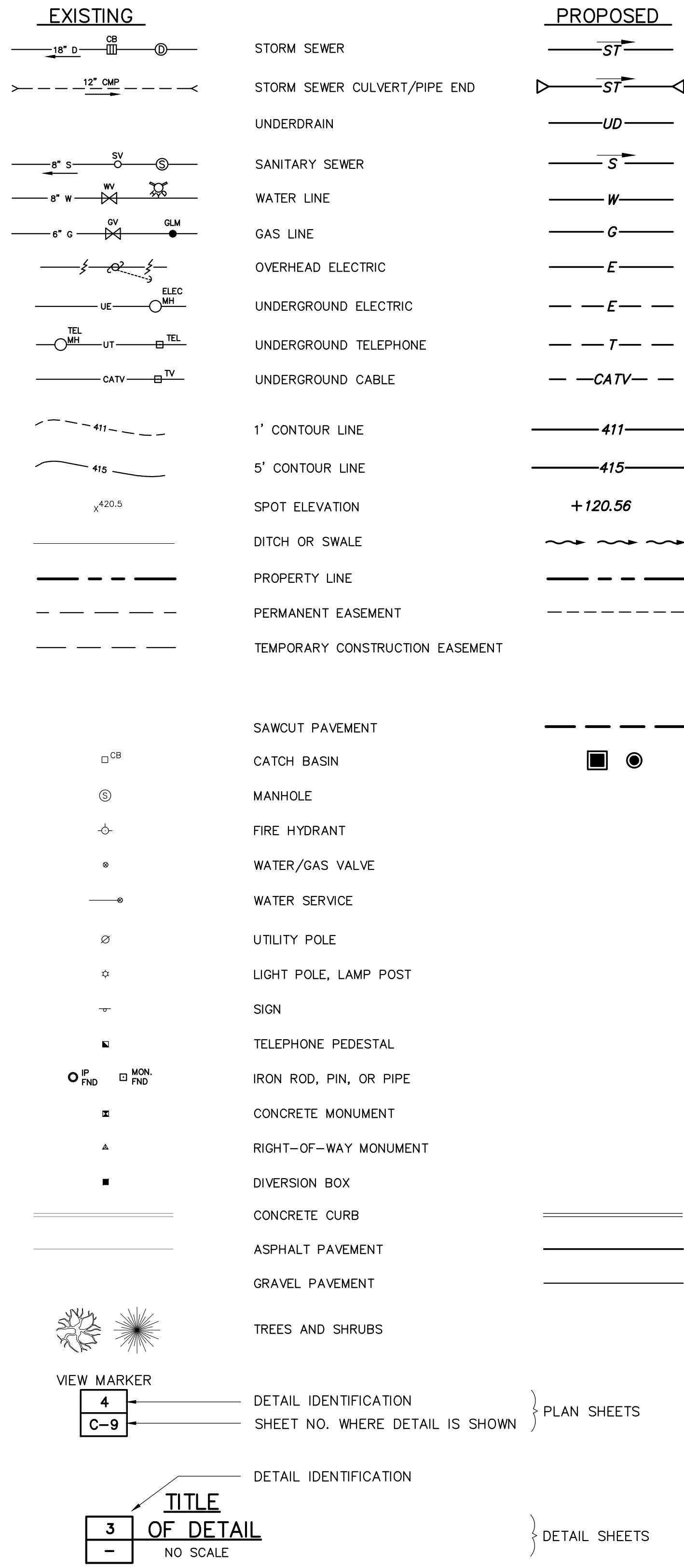

ABBREVIATIONS/ACRONYMS

AD	ALGEBRAIC DIFFERENCE
AOBE	AS ORDERED BY ENGINEER
BM	BENCH MARK
BVCE	BEGIN VERTICAL CURVE ELEVATION
BVCS	BEGIN VERTICAL CURVE STATION
CB	CATCH BASIN
CMP	CORRUGATED METAL PIPE
CO	CLEANOUT
CONC	CONCRETE
CY	CUBIC YARD
D	DIAMETER
DIA	DIAMETER
ELEV	ELEVATION
EST	ESTIMATED
EVCE	END VERTICAL CURVE ELEVATION
EVCS	END VERTICAL CURVE STATION
EX	EXISTING
FG	FINISHED GRADE
FT	FEET
GL	GUTTER LINE
GV	GAS VALVE
HDPE	HIGH DENSITY POLYETHYLENE
HYD	HYDRANT
IN	INCHES
INV	INVERT
L	LENGTH
LA	LANDSCAPED AREA
LF	LINEAR FEET
MAX	MAXIMUM
MH	MANHOLE
MIN	MINIMUM
MPT	MAINTENANCE & PROTECTION OF TRAFFIC
MUTCD	MANUAL OF UNIFORM TRAFFIC CONTROL DEVICES
NIC	NOT IN CONTRACT
NM	NIAGARA MOHAWK POWER CORPORATION
NO	NUMBER
NTS	NOT TO SCALE
NYS	NEW YORK STATE
NYSDOT	NEW YORK STATE DEPARTMENT OF TRANSPORTATION
OC	ON-CENTER
OCDOT	ONONDAGA COUNTY DEPARTMENT OF TRANSPORTATION
OCWA	ONONDAGA COUNTY WATER AUTHORITY
OD	OUTSIDE DIAMETER
PC	POINT OF CURVATURE
PI	POINT OF INTERSECTION
PT	POINT OF TANGENCY
PVI	POINT OF VERTICAL INTERSECTION
R	RADIUS
RCP	REINFORCED CONCRETE PIPE
RG	ROAD GRADE
ROW	RIGHT-OF-WAY
RT	ROUTE
SIM	SIMILAR TO
STA	STATION
TEL	TELEPHONE
TF	TOP OF FRAME
TYP	TYPICAL
UFPO	UNDERGROUND FACILITIES PROTECTIVE ORGANIZATION
UNO	UNLESS NOTED OTHERWISE
UTIL	UTILITY
VC	VERTICAL CURVE
VCP	VITRIFIED CLAY PIPE
WV	WATER VALVE

GENERAL NOTES

- BASE MAPPING PREPARED BY CONTROL POINT ASSOCIATED INC, P.C. DATED: JUNE 21, 2019.
- NORTH ORIENTATION AND CONTOURS ARE BASED ON GPS ESTABLISHED FROM PREVIOUS WORK PERFORMED IN THE AREA. REFERENCED TO NAD 83 (2011), NYS-CENTRAL (US FEET) AND NAVD 88 (US FEET) USING NYS DOT RTN SYSTEM. (REFERENCE CHA PROJECT #19646)
- UNDERGROUND UTILITIES ARE SHOWN FROM FIELD LOCATION IF POSSIBLE. OTHERS ARE SHOWN FROM RECORD DATA. THEIR EXACT LOCATION MAY DIFFER FROM THAT AS SHOWN AND OTHERS MAY EXIST.
- THE PREMISES SHOWN HEREON IS WITHIN ZONE "AE" (SPECIAL FLOOD HAZARD AREAS WITH BASE FLOOD ELEVATION). ACCORDING TO FEDERAL EMERGENCY MANAGEMENT AGENCY NATIONAL FLOOD INSURANCE PROGRAM FLOOD INSURANCE RATE MAP COMMUNITY PANELS NO. 36023C0227D & 36023C0229D, EFFECTIVE DATE: 03/02/2010.
- THE PLANS SHOW KNOWN SUBSURFACE STRUCTURES, ABOVE-GROUND STRUCTURES AND/OR UTILITIES BELIEVED TO EXIST IN THE WORKING AREA. EXACT LOCATION OF WHICH MAY VARY FROM THE LOCATIONS INDICATED. IN PARTICULAR, THE CONTRACTOR IS WARNED THAT THE EXACT OR EVEN APPROXIMATE LOCATION OF SUCH PIPELINES, SUBSURFACE STRUCTURES AND/OR UTILITIES IN THE AREA MAY BE DIFFERENT FROM THAT SHOWN OR MAY NOT BE SHOWN, AND IT SHALL BE HIS RESPONSIBILITY TO PROCEED WITH GREAT CARE IN EXECUTING ANY WORK. TWO (2) DAYS BEFORE YOU DIG, DRILL, OR BLAST, CALL DIG SAFELY NEW YORK. 1-800-962-7962 TOLL FREE.
- THE CONTRACTOR SHALL IMMEDIATELY NOTIFY THE OWNER'S REPRESENTATIVE, IN WRITING, OF ANY CONDITIONS THAT VARY FROM THOSE SHOWN ON THE PLANS. THE CONTRACTOR'S WORK SHALL NOT VARY FROM THE PLANS WITHOUT THE EXPRESSED APPROVAL OF THE OWNER'S REPRESENTATIVE.
- THE CONTRACTOR SHALL RESTORE LAWNS, DRIVEWAYS, CULVERTS, SIGNS AND OTHER PUBLIC OR PRIVATE PROPERTY DAMAGED OR REMOVED TO AT LEAST AS GOOD A CONDITION AS BEFORE BEING DISTURBED AS DETERMINED BY THE OWNER'S REPRESENTATIVE. ANY DAMAGED TREES, SHRUBS, AND/OR HEDGES SHALL BE REPLACED AT THE CONTRACTOR'S EXPENSE.
- THE CONTRACTOR SHALL PROTECT EXISTING PROPERTY LINE MONUMENTATION. ANY MONUMENTATION DISTURBED OR DESTROYED, AS JUDGED BY THE OWNER'S REPRESENTATIVE OR OWNER, SHALL BE REPLACED AT THE CONTRACTOR'S EXPENSE UNDER THE SUPERVISION OF A NEW YORK STATE LICENSED LAND SURVEYOR.
- IT IS THE CONTRACTOR'S RESPONSIBILITY TO EXAMINE ALL PLAN SHEETS AND SPECIFICATIONS. PRIOR TO COMMENCING CONSTRUCTION ACTIVITIES, CONTRACTOR SHALL NOTIFY THE OWNER'S REPRESENTATIVE IMMEDIATELY OF ANY ERRORS OR DISCREPANCIES.
- CONTRACTOR SHALL MAINTAIN FLOW FOR ALL EXISTING UTILITIES, CULVERTS, AND DITCHES.
- BEFORE CONSTRUCTING LINES TO CONNECT TO EXISTING UTILITIES OR UTILITIES INSTALLED UNDER OTHER CONTRACTS, VERIFY EXISTING UTILITY INVERTS AND NOTIFY OWNER'S REPRESENTATIVE IF ANY VARIATION FROM THE PLANS IS REQUIRED.
- THE CONTRACTOR SHALL EXERCISE CAUTION WHEN OPERATING CONSTRUCTION EQUIPMENT OVER NEW UTILITY TRENCHES. THE CONTRACTOR SHALL BE RESPONSIBLE FOR PLACING A MINIMUM OF TWO FEET OF COVER OVER UTILITY LINES PRIOR TO OPERATION OF TRACKED VEHICLES.
- THE CONTRACTOR SHALL IMPLEMENT ALL EROSION CONTROL MEASURES IN STRICT ACCORDANCE WITH THE PLAN AND SCHEDULE SET OUT IN THESE PLANS AND THE DESIGN SPECIFICATIONS.
- THE CONTRACTOR SHALL:
 - VERIFY ALL CONDITIONS IN THE FIELD PRIOR TO COMMENCEMENT OF WORK AND NOTIFY THE OWNER AND OWNER'S REPRESENTATIVE OF ANY DISCREPANCIES.
 - NOTIFY UFPO FOR UTILITY MARK-OUT AT LEAST TWO DAYS PRIOR TO BEGINNING CONSTRUCTION.
 - EXAMINE THE SITE AND INCLUDE IN HIS/HER WORK THE EFFECT OF ALL EXISTING CONDITIONS ON THE WORK.
 - PROVIDE AND INSTALL ALL MATERIALS AND PERFORM ALL WORK IN ACCORDANCE WITH RECOGNIZED GOOD STANDARD PRACTICE.
 - HOLD THE OWNER HARMLESS AGAINST ANY AND ALL CLAIMS ARISING FROM WORK DONE BY THE CONTRACTOR ON SITE.
- ALL WORK SHALL BE DONE IN STRICT COMPLIANCE WITH ALL APPLICABLE NATIONAL, STATE, AND LOCAL CODES, STANDARDS, ORDINANCES, RULES, AND REGULATIONS.
- THE OWNER'S REPRESENTATIVE RESERVES THE RIGHT TO EXAMINE ANY WORK DONE ON THIS PROJECT AT ANY TIME TO DETERMINE THE CONFORMANCE WITH THE REQUIREMENTS OF THE CONTRACT DOCUMENTS OF THIS PROJECT, AS INDICATED AND INTENDED BY THE OWNER'S REPRESENTATIVE.
- THE CONTRACTOR SHALL BE RESPONSIBLE FOR OBTAINING AND INCURRING THE COST OF ALL REQUIRED PERMITS, INSPECTIONS, CERTIFICATES, ETC. AND SHALL COMPLY WITH ALL REQUIRED PERMITS.
- ALL PROPOSED UTILITIES AND APPURTENANCES TO BE CONSTRUCTED IN COMPLIANCE WITH THE LOCAL MUNICIPALITIES' CODES AND REGULATIONS GOVERNING THE INSTALLATION OF SUCH UTILITIES.
- THE CONTRACTOR SHALL BE RESPONSIBLE FOR CONDUCTING EXPLORATORY TEST PITS AS REQUIRED TO DETERMINE UNDERGROUND CONDITIONS. THE CONTRACTOR SHALL CONDUCT TEST PITS AS REQUIRED FOR PERFORMANCE OF WORK AT THE CONTRACTOR'S EXPENSE.
- THE CONTRACTOR SHALL BE RESPONSIBLE FOR PROVIDING ALL FIELD LAYOUT. THE CONTRACTOR SHALL TAKE TIES TO ALL UTILITY CONNECTIONS AND PROVIDE MARKED-UP RECORD DRAWINGS FOR ALL UTILITIES SHOWING TIES TO CONNECTIONS, BENDS, VALVES, LENGTHS OF LINES, AND INVERTS. RECORD DRAWINGS SHOWING ALL UNDERGROUND UTILITIES INSTALLED OR ENCOUNTERED SHALL BE REVIEWED BY THE OWNER'S REPRESENTATIVE. THE CONTRACTOR SHALL PROVIDE ANY CORRECTIONS OR OMISSIONS TO THE SATISFACTION OF THE OWNER'S REPRESENTATIVE BEFORE UTILITIES WILL BE ACCEPTED.
- ALL UTILITY WORK INVOLVING CONNECTIONS TO EXISTING SYSTEMS SHALL BE COORDINATED WITH THE OWNER'S REPRESENTATIVE AND THE UTILITY OWNER. NOTIFY THE OWNER'S REPRESENTATIVE AND THE UTILITY OWNER 72 HOURS BEFORE EACH AND EVERY CONNECTION TO EXISTING SYSTEMS IS MADE. CONTRACTOR SHALL BE REQUIRED TO NOTIFY PROPERTY OWNERS, IN WRITING, 72 HOURS IN ADVANCE OF ANY INTERRUPTION IN UTILITY SERVICES.
- THE CONTRACTOR SHALL TAKE CARE TO PREVENT DAMAGE TO ANY UTILITIES, ESPECIALLY WHEN OPERATING EQUIPMENT NEAR UTILITY LINES. DAMAGED UTILITIES SHALL BE IMMEDIATELY REPAIRED BY CONTRACTOR AT THE CONTRACTOR'S EXPENSE.
- ALL FRAMES/COVERS, CASTINGS, VALVE BOXES, ETC. WITHIN PAVED AREAS SHALL HAVE THE TOPS SET 0.1' BELOW THE FINAL PAVEMENT GRADE. IN ALL LANDSCAPED AND GRASS AREAS, ALL FRAMES SHALL BE 0.1' ABOVE GRADE.
- ALL TRENCH EXCAVATION AND ANY REQUIRED SHEETING AND SHORING SHALL BE DONE IN ACCORDANCE WITH THE LATEST REVISIONS OF NEW YORK STATE INDUSTRIAL CODE RULE 23 AND OSHA REGULATIONS FOR CONSTRUCTION. SHEET PILING SHALL BE DESIGNED AND SEALED BY A NEW YORK STATE PROFESSIONAL ENGINEER.
- CONTRACTOR SHALL BE RESPONSIBLE FOR DEWATERING AND THE MAINTENANCE OF SURFACE DRAINAGE DURING THE COURSE OF THE WORK. THE CONTRACTOR SHALL SUBMIT A DEWATERING PLAN DESIGNED AND SEALED BY A NEW YORK STATE PROFESSIONAL ENGINEER. THE CONTRACTOR SHALL MAINTAIN EXISTING SITE DRAINAGE PATTERNS THROUGHOUT CONSTRUCTION.
- ALL SITE FILL SHALL BE PLACED IN ACCORDANCE WITH THE PLANS AND SPECIFICATIONS UNLESS NOTED OTHERWISE.
- ALL BACKFILL USED IN TRENCHES EXCAVATED IN EXISTING ROADWAYS SHALL BE RUN OF CRUSHER HARD DURABLE LIMESTONE AND PLACED IN MAXIMUM 6-INCH LIFTS AND COMPACTED BY MEANS OF A MECHANICAL COMPACTOR BETWEEN LIFTS.
- ALL BACKFILL MATERIALS LOCATED UNDER PROPOSED PAVEMENT ARE REQUIRED TO BE COMPACTED 95% OF MODIFIED PROCTOR DENSITY VALUE AS PER ASTM D-1157.
- WHEN BACKFILLING AROUND PROPOSED OR EXISTING STRUCTURES, MATERIAL SHALL BE PLACED IN MAXIMUM 6-INCH LIFTS AND COMPACTED BY MEANS OF A MECHANICAL COMPACTOR BETWEEN LIFTS.
- PERMANENT OR TEMPORARY PAVEMENT SHALL BE PLACED WITHIN 48 HOURS OF THE COMPLETION OF BACKFILL OPERATIONS WITHIN THE PAVEMENT AREAS.
- CONTRACTOR SHALL MAINTAIN ALL TRAFFIC IN AREAS IN ACCORDANCE WITH THE NYS DOT "MANUAL OF UNIFORM TRAFFIC CONTROL DEVICES," AND SECTION 619 OF NYS DOT'S STANDARD SPECIFICATIONS. CONTRACTOR SHALL BE RESPONSIBLE FOR COORDINATING ALL WORK, LANE CLOSURES, AND DISRUPTIONS WITH THE OWNER AND OTHER GOVERNING OR APPLICABLE AGENCIES.
- CONTRACTOR SHALL MAINTAIN ACCESS TO ALL COMMERCIAL, RESIDENTIAL, AND PUBLIC PROPERTIES WHENEVER POSSIBLE AND/OR AS DIRECTED BY THE OWNER'S REPRESENTATIVE.
- ALL DRIVEWAYS AND SIDE STREETS SHALL BE MADE ACCESSIBLE BY THE CONTRACTOR AT THE END OF EACH DAY THAT WORK IS PERFORMED. ALL EXCAVATIONS SHALL BE BACKFILLED TO EXISTING GRADE AT THE END OF EACH WORK DAY.
- THE CONTRACTOR IS TO EXERCISE ALL POSSIBLE CAUTION WHILE WORKING IN THE VICINITY OF EXISTING TREES. ANY DAMAGE TO TREES DURING CONSTRUCTION ACTIVITIES IS THE RESPONSIBILITY OF THE CONTRACTOR.
- MISCELLANEOUS WORK NOT SPECIFICALLY SHOWN ON THE CONTRACT DRAWINGS SUCH AS PATCHING, BLOCKING, TRIMMING, ETC. SHALL BE PERFORMED BY THE CONTRACTOR TO MAKE THE WORK COMPLETE.
- ALL ROADS SHALL BE KEPT CLEAN OF DEBRIS AT ALL TIMES. CLEAN AND SWEEP ALL EXISTING AND NEW PAVEMENTS AND/OR LANES AS PART OF THIS PROJECT PRIOR TO OPENING TO TRAFFIC AND AT THE END OF THE DAY FOR EACH CONSTRUCTION ACTIVITY.
- MATERIALS, EQUIPMENT AND VEHICLES ARE NOT TO BE STORED OR PARKED WITHIN ANY HIGHWAY RIGHT-OF-WAY.

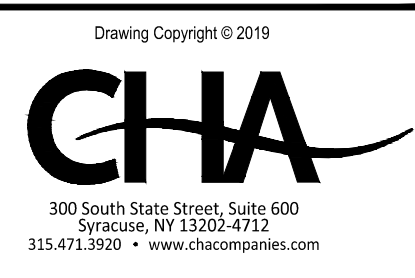

APPLICANT:
USED CAR KING, LLC
 8010 BREWERTON RD
 CICERO, NY 13039

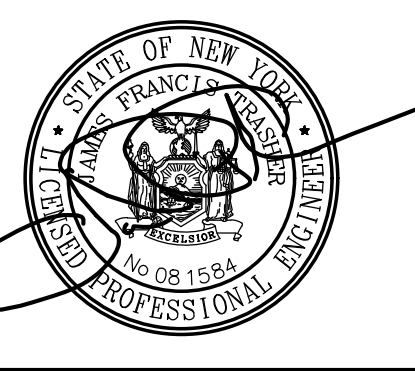

IT IS A VIOLATION OF LAW FOR ANY PERSON, UNLESS THEY ARE ACTING UNDER THE SUPERVISION OF A LICENSED PROFESSIONAL ENGINEER, ARCHITECT, LANDSCAPE ARCHITECT OR LAND SURVEYOR, TO ALTER AN ITEM IN ANY WAY IF AN ITEM BEARING THE STAMP OF A LICENSED PROFESSIONAL IN A DIRECT OR INDIRECT MANNER. ANY SUCH ALTERATION SHALL BE CONSIDERED A VIOLATION OF THE PROFESSIONAL SEAL ACT AND SHALL BE PENALIZED BY THE STATE OF NEW YORK. THE DATE OF SUCH ALTERATION AND A SPECIFIC DESCRIPTION OF THE ALTERATION.

PROJECT:
PROPOSED PARKING LOT MODIFICATIONS
 3845 & 3861 WEST RD
 CORTLANDVILLE, NY 13045

No.	Submitted / Revision	Date	Appr'd. By
0	Town of Cortlandville Submittal	09/26/19	JFT / AMV

LEGEND AND GENERAL NOTES		
Designed By:	Drawn By:	Checked By:
AMV	AMV	JFT
Issue Date:	Project No:	Scale:
9/26/19	58214	AS SHOWN

Drawing No.:
C-02

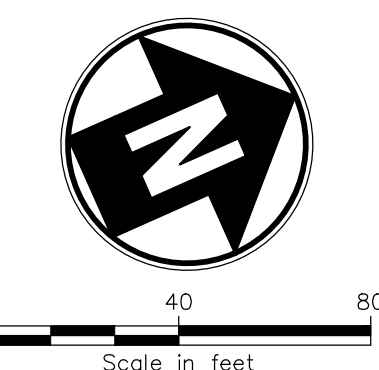

APPLICANT:
USED CAR KING, LLC
8010 BREWERTON RD
CICERO, NY 13039



IT IS A VIOLATION OF LAW FOR ANY PERSON, UNLESS THEY ARE ACTING UNDER THE SUPERVISION OF A LICENSED PROFESSIONAL ENGINEER, ARCHITECT, LANDSCAPE ARCHITECT OR LAND SURVEYOR TO ALTER IN ANY WAY, IF AN ITEM BEARING THE STAMP OF A LICENSED PROFESSIONAL ENGINEER OR ARCHITECT, ENGINEER, ARCHITECT, LANDSCAPE ARCHITECT OR LAND SURVEYOR SHALL BE MADE. THE DOCUMENT AND ALL NOTATIONS ALTERED BY FOLLOWING BY THEIR SIGNATURE, THE DATE OF SUCH ALTERATION, AND A SPECIFIC DESCRIPTION OF THE ALTERATION.

PROJECT:
PROPOSED PARKING LOT MODIFICATIONS
3845 & 3861 WEST RD
CORTLANDVILLE, NY 13045

No.	Submitted / Revision	Apprv. By	Date
0	Town of Cortlandville Submittal	JFT / AMV	09/26/19

EXISTING CONDITIONS & DEMOLITION PLAN

Designed By: AMV	Drawn By: AMV	Checked By: JFT
Issue Date: 9/26/19	Project No: 58214	Scale: AS SHOWN

Drawing No.:
C-03

File: V:\PROJECTS\NY\K5\058214\000\CADD\ACAD\CIVIL\SHR214_C-03-DEM.DWG
Saved: 9/26/2019 2:48:40 PM Plotted: 9/26/2019 2:57:04 PM Current User: Vitale, Anthony, LostSwatby: 4, 338

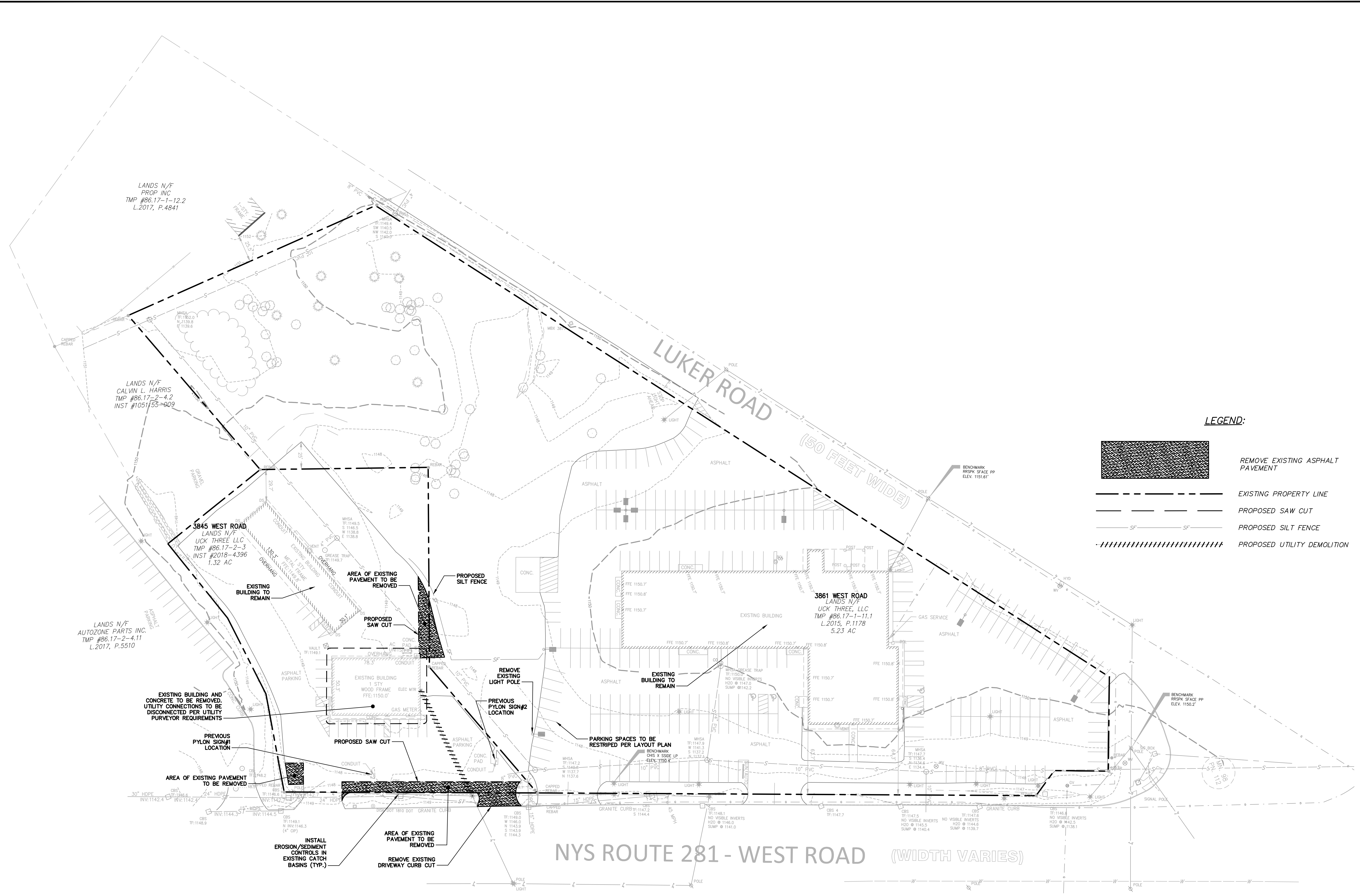

LEGEND:

- REMOVE EXISTING ASPHALT PAVEMENT
- EXISTING PROPERTY LINE
- PROPOSED SAW CUT
- PROPOSED SILT FENCE
- PROPOSED UTILITY DEMOLITION

ZONING REGULATIONS FOR DEVELOPMENT

EXISTING LOT INFORMATION:

ADDRESS	TAX MAP	ACREAGE
3861 WEST (RTE 281)	86.17-01-11.1	±5.23 AC
3845 WEST (RTE 281)	86.17-02-03.0	±1.32 AC

EXISTING ZONING: PLANNED COMMERCIAL BUSINESS B-3 DISTRICT

WELLHEAD PROTECTION ZONE: ZONE 1A

COVERAGE REQUIREMENTS: (SEE LANDSCAPING PLAN)

PARKING SPACE COUNT:

LOT	EXISTING SPACES	PROPOSED SPACES	+/- CHANGE
01-11.1	259	267	+8
02-03.0	100	92	-8

PARKING REQUIREMENTS: **REQUIRED** **PROVIDED**

PARKING SPACE SIZE: 10' X 20' 10' X 20'

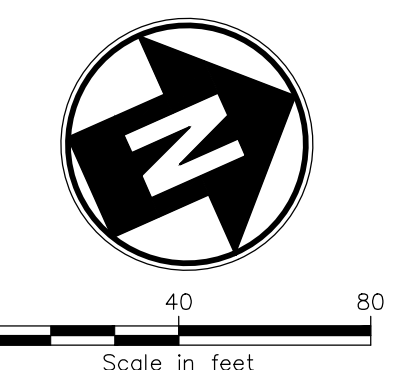
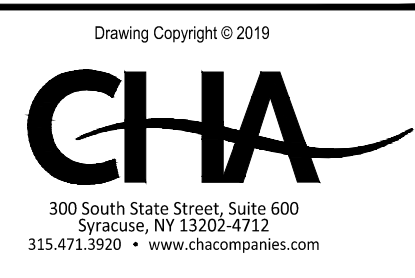

APPLICANT:
USED CAR KING, LLC
8010 BREWERTON RD
CICERO, NY 13039



IT IS A VIOLATION OF LAW FOR ANY PERSON, UNLESS THEY ARE ACTING UNDER THE SUPERVISION OF A LICENSED PROFESSIONAL ENGINEER, ARCHITECT, LANDSCAPE ARCHITECT OR LAND SURVEYOR, TO ALTER IN ANY WAY, IF AN ITEM BEARING THIS STAMP OF A LICENSED PROFESSIONAL ENGINEER OR LAND SURVEYOR SHALL BEAM, THE DOCUMENT AND INCLUDE THE NOTATION "ALTERED BY" FOLLOWED BY THEIR SIGNATURE, THE DATE OF SUCH ALTERATION, AND A SPECIFIC DESCRIPTION OF THE ALTERATION.

PROJECT:
PROPOSED PARKING LOT MODIFICATIONS
3845 & 3861 WEST RD
CORTLANDVILLE, NY 13045

No.	Submitted / Revision	Appr'd By	Date
0	Town of Cortlandville Submittal	JFT / AMV	09/26/19

LAYOUT PLAN

Designed By:	Drawn By:	Checked By:
AMV	AMV	JFT
Issue Date:	Project No:	Scale:
9/26/19	58214	AS SHOWN

Drawing No.:
C-04

File: V:\PROJECTS\NY\5\058214\000\CADD\ACAD\DWG\SHRHEET FILES\58214_C-04-LAY1.DWG
Saved: 9/24/2019 3:56:30 PM. Plotted: 9/26/2019 2:57:39 PM. Current User: Vitale, Anthony, LostSweddy: 4.338

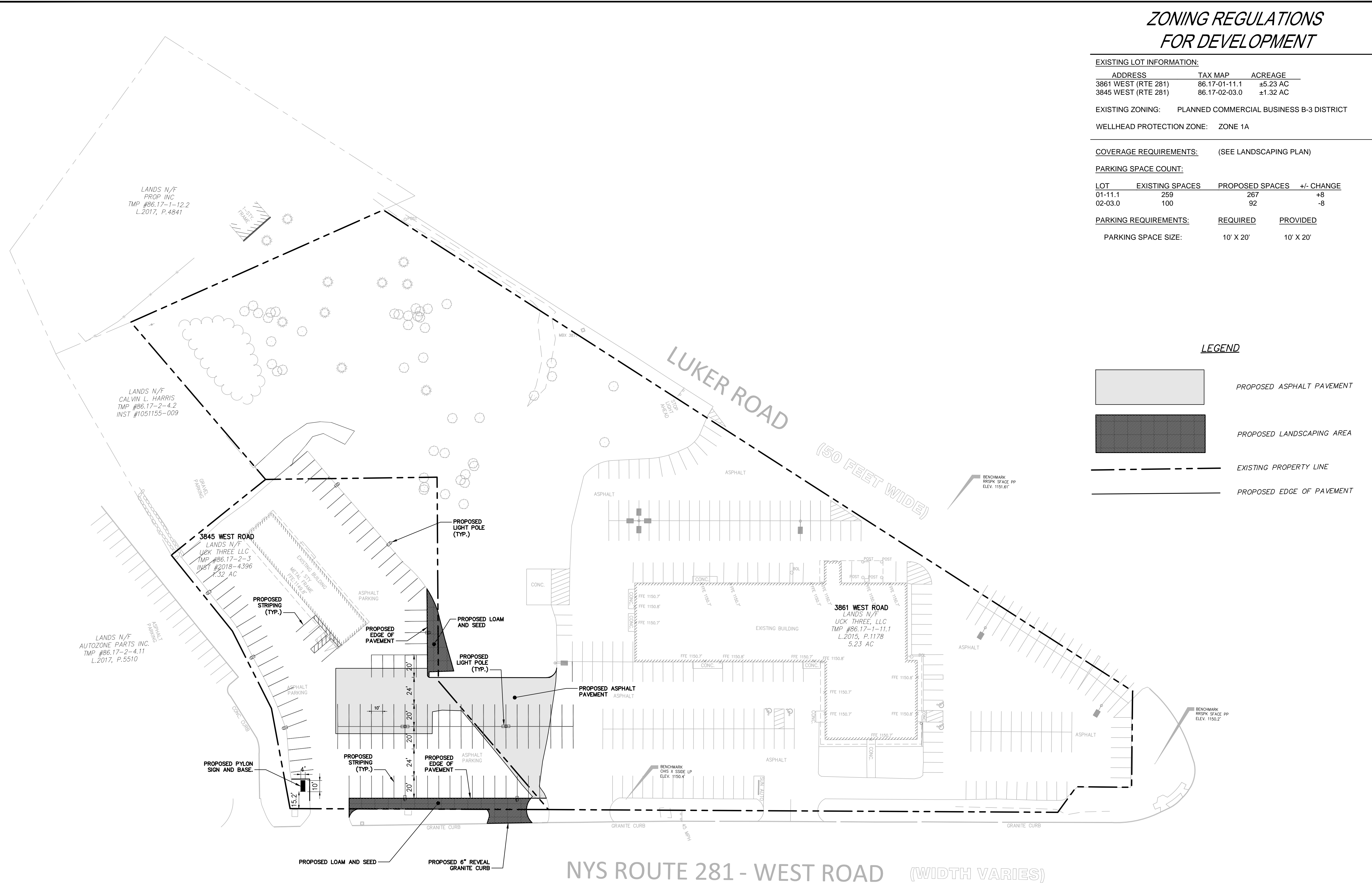

LEGEND

- PROPOSED ASPHALT PAVEMENT
- PROPOSED LANDSCAPING AREA
- EXISTING PROPERTY LINE
- PROPOSED EDGE OF PAVEMENT

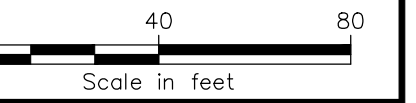
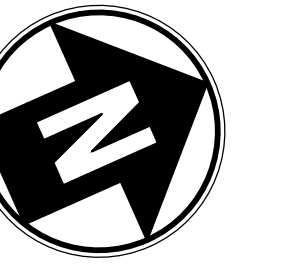

APPLICANT:
USED CAR KING, LLC
8010 BREWERTON RD
CICERO, NY 13039



IT IS A VIOLATION OF LAW FOR ANY PERSON, UNLESS THEY ARE ACTING UNDER THE SUPERVISION OF A LICENSED PROFESSIONAL ENGINEER, ARCHITECT, LANDSCAPE ARCHITECT OR LAND SURVEYOR, TO ALTER AN ITEM IN ANY WAY IF AN ITEM BEARING THE STAMP OF A LICENSED PROFESSIONAL ENGINEER OR ARCHITECT, ENGINEER, ARCHITECT, LANDSCAPE ARCHITECT OR LAND SURVEYOR SHALL STAMP THE DOCUMENT AND INCLUDE THE NOTATION "ALTERED BY" FOLLOWED BY THEIR SIGNATURE, THE DATE OF SUCH ALTERATION, AND A SPECIFIC DESCRIPTION OF THE ALTERATION.

PROJECT:
PROPOSED PARKING LOT MODIFICATIONS
3845 & 3861 WEST RD
CORTLANDVILLE, NY 13045

No.	Submitted / Revision	Appr'd By	Date
0	Town of Cortlandville Submittal	JFT / AMV	09/26/19

LANDSCAPING PLAN

Designed By: AMV	Drawn By: AMV	Checked By: JFT
Issue Date: 9/26/19	Project No: 58214	Scale: AS SHOWN

Drawing No.:
C-05

WELLHEAD PROTECTION ZONE

EXISTING LOT INFORMATION:

ADDRESS	TAX MAP	ACREAGE
3861 WEST RD (RTE 281)	86.17-01-11.1	±5.23 AC (227,840 SF)
3845 WEST RD (RTE 281)	86.17-02-03.0	±1.32 AC (57,310 SF)

EXISTING ZONING: PLANNED COMMERCIAL BUSINESS B-3 DISTRICT

WELLHEAD PROTECTION ZONE: ZONE 1A

COVERAGE REQUIREMENTS: PER CODE EXISTING PROPOSED

	PER CODE	EXISTING	PROPOSED
LOT 11.1 MAX. LOT COVERAGE:	50%	55%	57% (2% INCREASE)
LOT 3 MAX. LOT COVERAGE:	50%	85%	82% (3% REDUCTION)
COMBINED LOT	50%	61%	62% (1% INCREASE)

LOT 11.1 COVERAGE:
PRE-DEVELOPMENT IMPERVIOUS AREA: 125,425 SF (2.88 AC)
POST-DEVELOPMENT IMPERVIOUS AREA: 130,890 SF (3.00 AC)
TOTAL NET NEW IMPERVIOUS: 5,465 SF

LOT 3 COVERAGE:
PRE-DEVELOPMENT IMPERVIOUS AREA: 48,775 SF (1.12 AC)
POST-DEVELOPMENT IMPERVIOUS AREA: 47,230 SF (1.08 AC)
TOTAL NET NEW IMPERVIOUS: -1,545 SF

COMBINED LOT COVERAGE:
PRE-DEVELOPMENT IMPERVIOUS AREA: 174,200 SF (4.00 AC)
POST-DEVELOPMENT IMPERVIOUS AREA: 178,120 SF (4.09 AC)
TOTAL NET NEW IMPERVIOUS: 3,920 SF

LEGEND:

- PROPOSED IMPERVIOUS AREA
- PROPOSED VEGETATED RESTORATION AREA
- EXISTING PROPERTY LINE

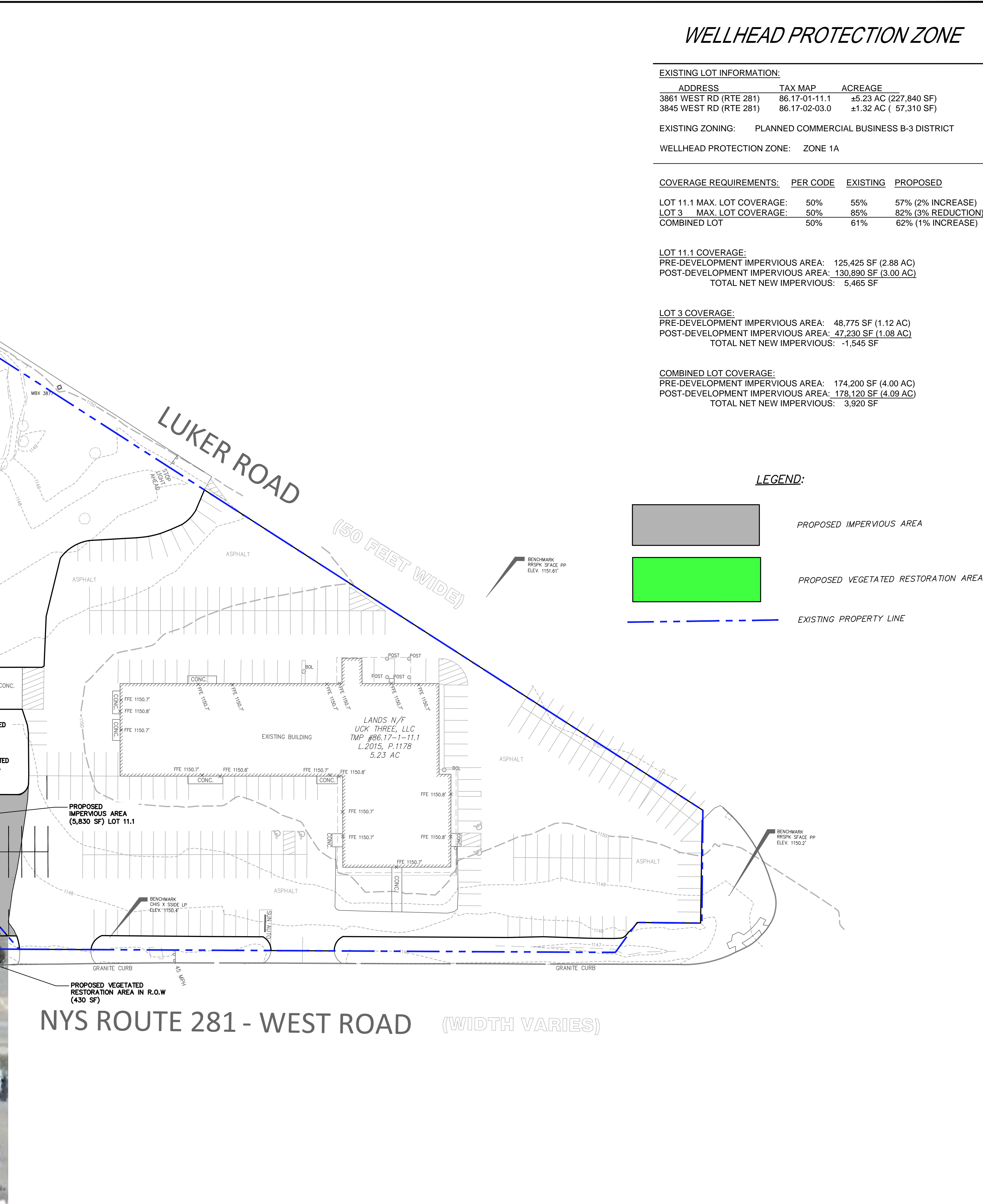
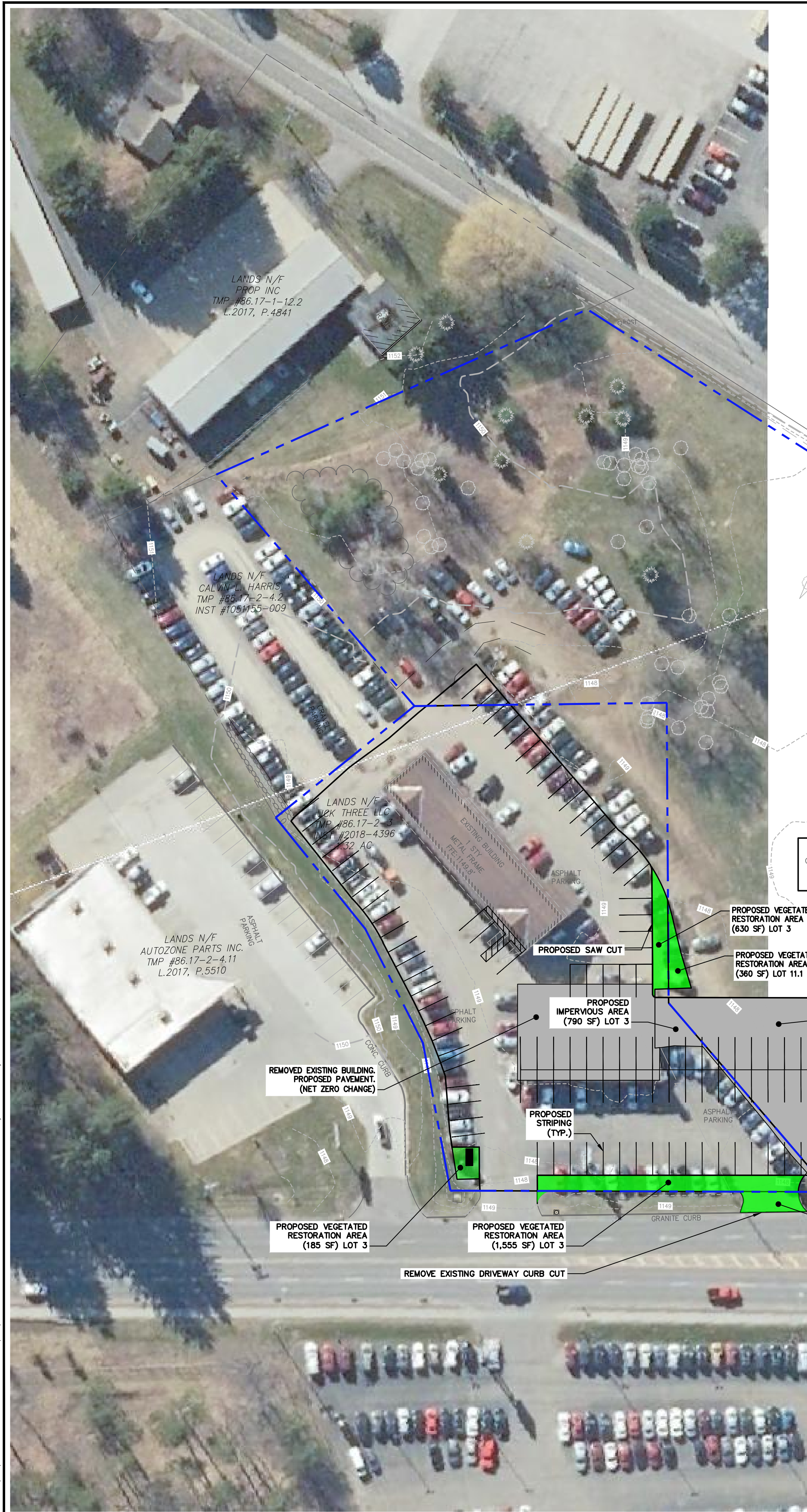

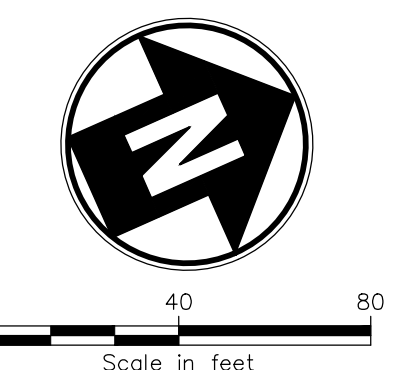

APPLICANT:
USED CAR KING, LLC
8010 BREWERTON RD
CICERO, NY 13039



IT IS A VIOLATION OF LAW FOR ANY PERSON, UNLESS THEY ARE ACTING UNDER THE SUPERVISION OF A LICENSED PROFESSIONAL ENGINEER, ARCHITECT, LANDSCAPE ARCHITECT OR LAND SURVEYOR, TO ALTER IN ANY WAY, IF AN ITEM BEARING THE STAMP OF A LICENSED PROFESSIONAL ENGINEER OR LAND SURVEYOR SHALL STAMP THE DOCUMENT AND INCLUDE THE NOTATION "ALTERED BY FOLLOWED BY THEIR SIGNATURE, THE DATE OF SUCH ALTERATION, AND A SPECIFIC DESCRIPTION OF THE ALTERATION."

PROJECT:
PROPOSED PARKING LOT MODIFICATIONS
3845 & 3861 WEST RD
CORTLANDVILLE, NY 13045

No.	Submitted / Revision	Appr'd. By	Date
0	Town of Cortlandville Submittal	JFT / AMV	09/26/19

LIGHTING & SIGNAGE PLAN

Designed By: AMV	Drawn By: AMV	Checked By: JFT
Issue Date: 9/26/19	Project No: 58214	Scale: AS SHOWN

Drawing No.:
C-06



8 SF EACH SIDE

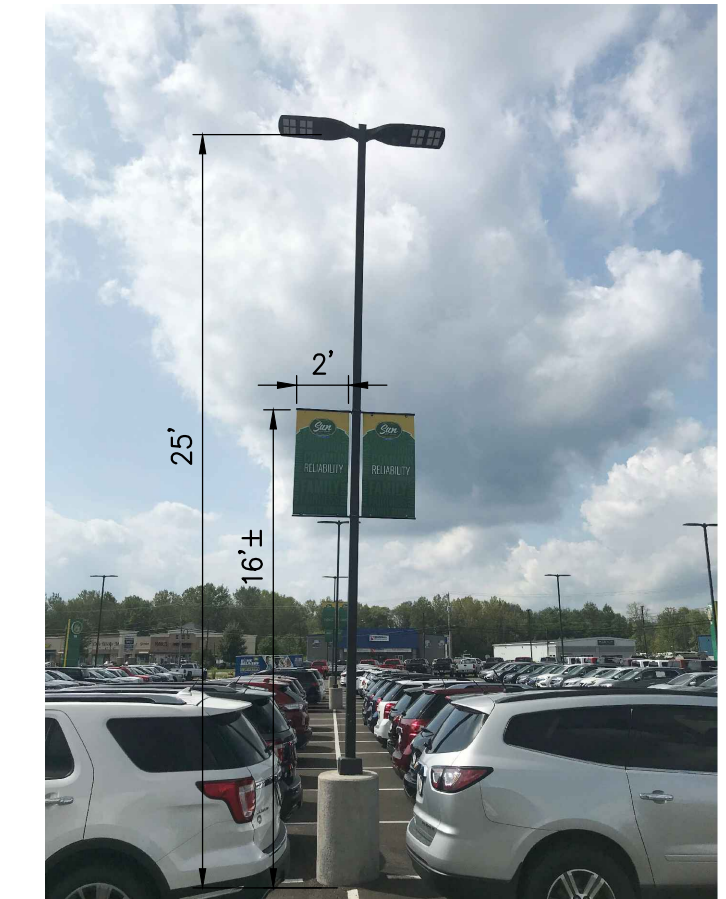

TYPICAL INSTALLATION



25' MOUNTING HEIGHT

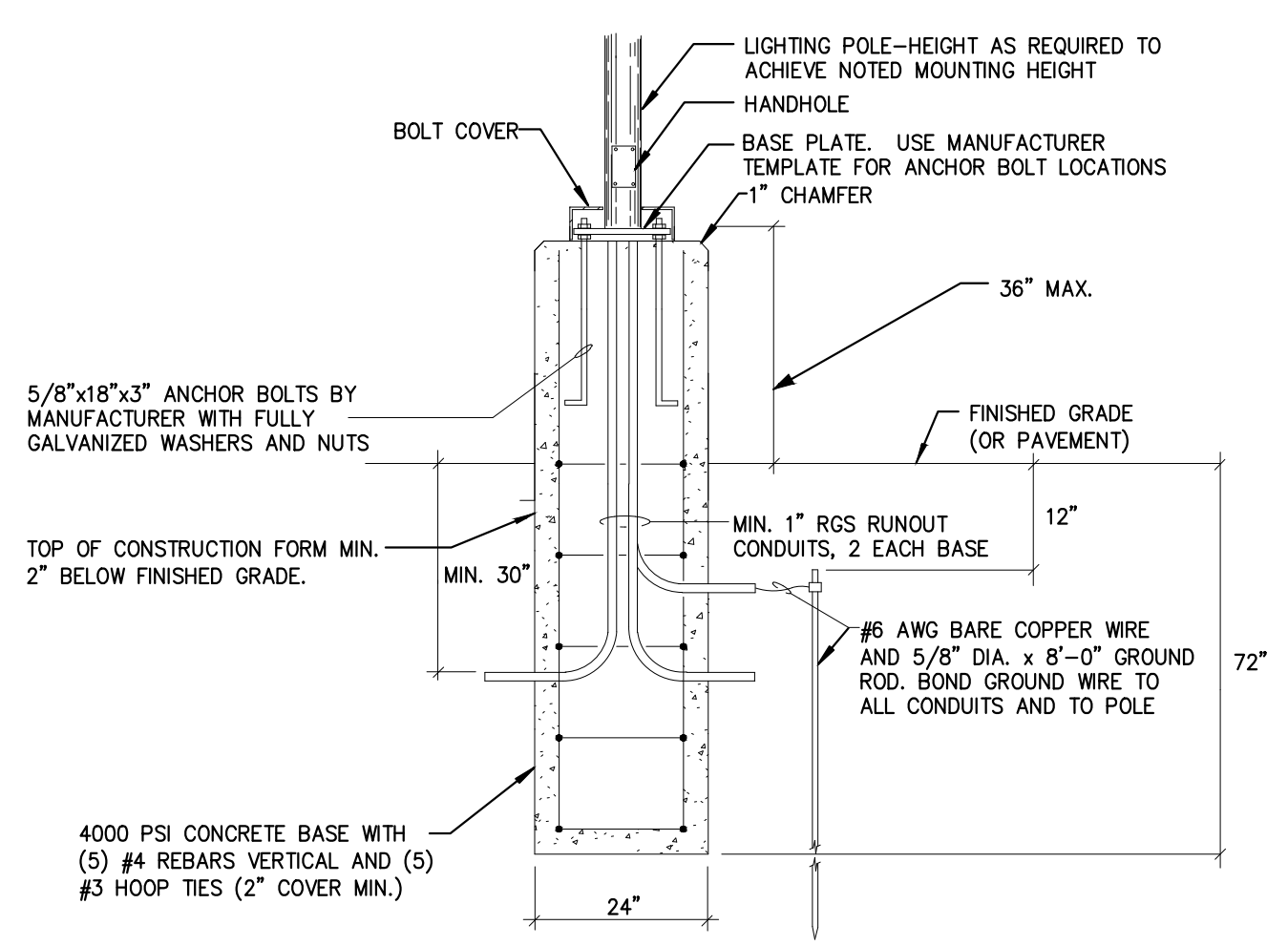

3 LIGHT POLE BASE
SCALE: N.T.S.

1 PROPOSED LIGHT POLE SIGN
SCALE: N.T.S.

LIGHT POLE QUANTITIES:
LOT 11.1: 12 (11 EX + 1 NEW)
LOT 3: 10 NEW
TOTAL: 22 POLES

LEGEND
⊕ LIGHT POLES WITH PROPOSED SIGNS

LIGHT POLE SIGN QUANTITIES:
LOT 11.1: 7
LOT 3: 4
TOTAL: 11 POLES

2 LIGHT FIXTURE
SCALE: N.T.S.



4 PROPOSED PYLON SIGN
SCALE: N.T.S.

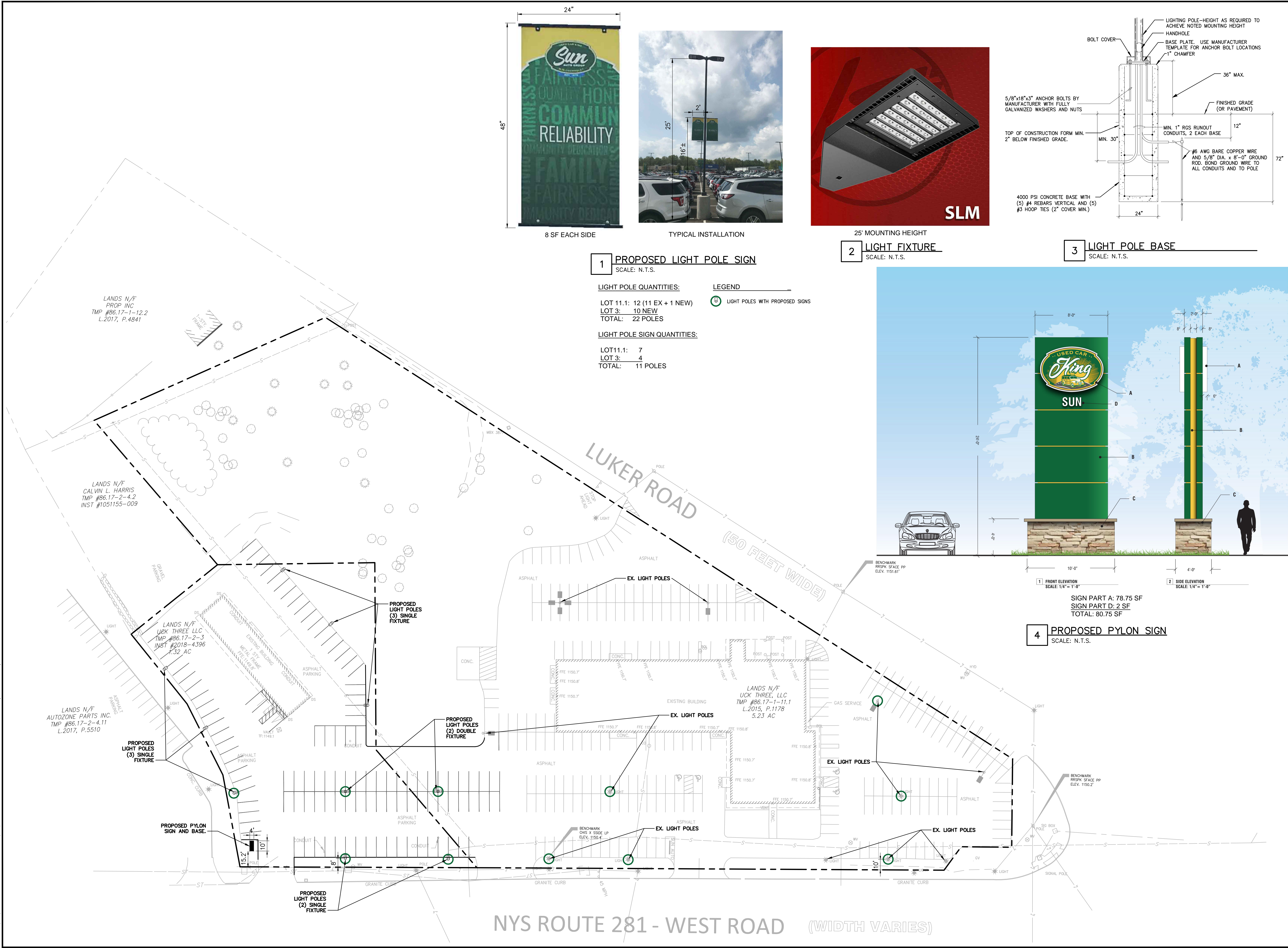

File: V:\PROJECTS\NY\K5\058214_000\CADD\CIVIL\SHEET FILES\58214_C-06-LIGHT_SIGN.DWG
Saved: 9/26/2019 3:00:53 PM Plotted: 9/26/2019 3:15:20 PM Current User: Vitale, Anthony LastSayedBy: 4138